

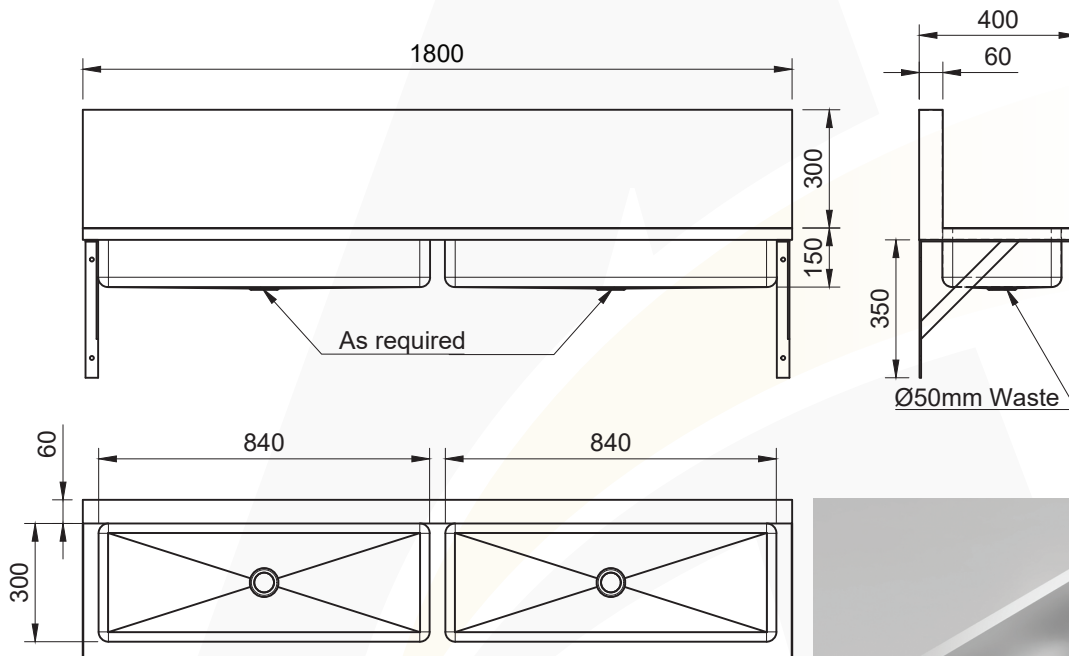

WALL MOUNTED ABLUTION TROUGH

2



2.13



SKU CODE: ASS-WMAT

This quality custom made wall mounted abluion trough is frequently used in practical activity classrooms. Half of the trough is for hand washing whilst the other is for clay, plaster or soil. Supplied with wall mounting brackets for easy installation. It can be manufactured to required lengths.

SPECIFICATIONS:

- Made from 1.2mm, 304 grade stainless steel
- Outlet position and length as required
- Standard height splashback as required
- 50mm outlets
- Plug and waste provided

USES:

- Educational facilities
- Art Studios





SIGN-OFF FORM

Company:

Name:

Phone:

Email:

Purchase Order #:

Date:/...../.....

Signature*:

Quantity:

Length:

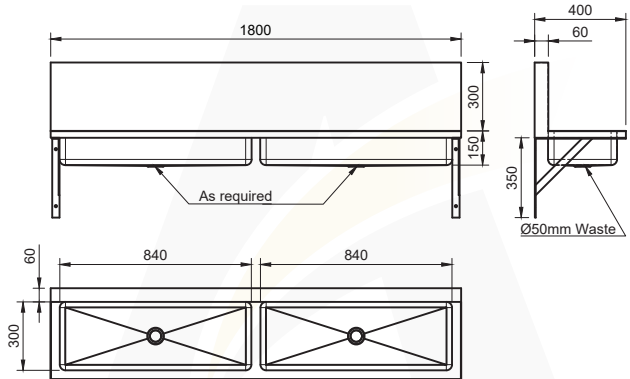

Stainless steel grade: 304 316 (extra charges)

ASS-WMAT (Wall Mounted Ablution Trough)

For LEFT Trough:

Internal dimensions: Length: mm Width: mm Depth: mm

Outlet size: 50mm 90 mm

Outlet position: Centre Left mm Right mm
(From the LEFT or RIGHT hand side to the centre of the outlet)

For RIGHT Trough:

Internal dimensions: Length: mm Width: mm Depth: mm

Outlet size: 50mm 90 mm

Outlet position: Centre Left mm Right mm
(From the LEFT or RIGHT hand side to the centre of the outlet)

Tap hole: No Yes - Number of tap holes:

Tap hole size: 22mm 25mm 30mm 32mm 35mm

EXTRAS (Additional costs):

External radius corners: Yes No

Pre-plumbing: Yes No

Custom splashback height:mm

Free standing frame height:mm

Tap hole position drawing in (mm) below:

**By submitting this form you declare that the details provided in this Sign-Off Form are accurate and will be used to manufacture your product. In the event that incorrect details have been provided, Advance Stainless Steel will not be held liable for these errors. All custom made orders cannot be returned and are non-refundable. The lead time is between 10-15 working days plus delivery.*