

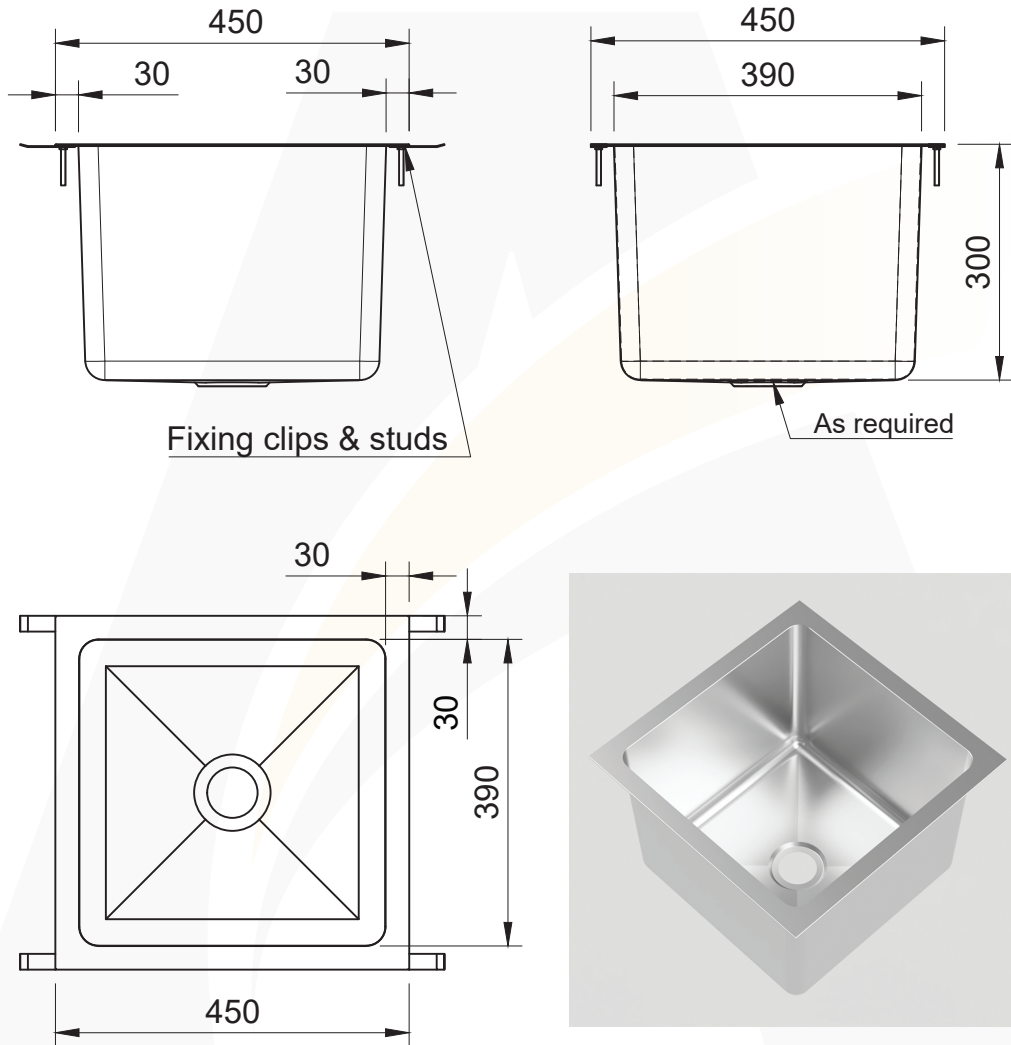

# LABORATORY SINK

5



Fixing clips & studs

As required

5.3

## SKU CODE: ASS-LS

This quality custom made laboratory sink is manufactured from 1.2mm thickness and in 316 grade stainless steel. The sink can be dropped-in or undermounted to a wide range of benchtops.

### SPECIFICATIONS:

- Made in 1.2mm
- 316 grade stainless steel
- Outlet position and length as required
- Fixing studs

### USES:

- Aged / Health care
- Hospitals
- Schools/ Labs





# SIGN-OFF FORM

Company: .....

Name: .....

Phone: .....

Email: .....

Purchase Order #: .....

Date: ...../...../.....

Signature\*: .....

Quantity: .....

Stainless steel grade:  304 (budget)  316

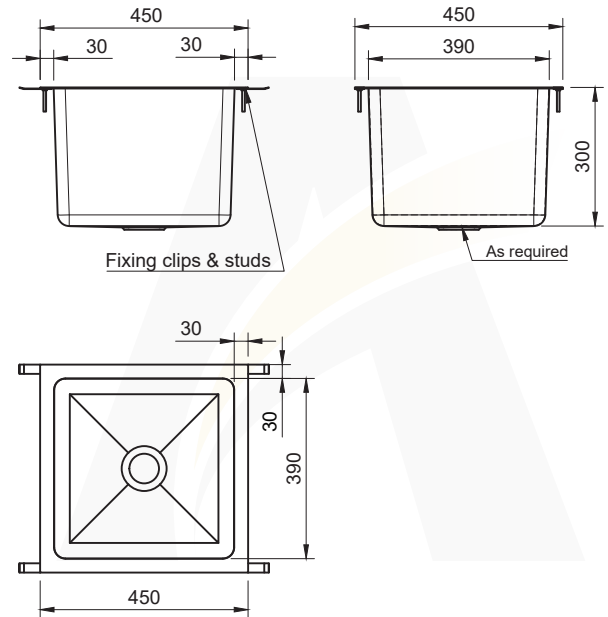

## ASS-LS (Laboratory Sink)

Internal dimensions: **Length:** ..... mm **Width:** ..... mm **Depth:** ..... mm

Flange size:  25mm  30 mm  Other: ..... mm

Outlet size:  50mm  90 mm

Outlet position:  Centre **OR**  
 Custom: ..... mm from Left / Right to the centre of the outlet **AND**  
..... mm from Rear to the centre of the outlet

Internal Corners:  Square corners  25mm Radius corners

Application:  Domestic  Commercial

Fixing clips:  Yes  No

*\*By submitting this form you declare that the details provided in this Sign-Off Form are accurate and will be used to manufacture your product. In the event that incorrect details have been provided, Advance Stainless Steel will not be held liable for these errors. All custom made orders cannot be returned and are non-refundable. The lead time is between 10-15 working days plus delivery.*